



INSTRUCTION MANUAL

IMPORTANT: Read This Instruction Manual Completely before operating this equipment. Save this manual and keep it handy for quick reference. Pay particular attention to the hazards and safety precautions provided for your protection and for the protection of those in the immediate vicinity where this device is to be used. Contact your distributor if you do not fully understand this manual or require additional information.

© 2021 Global Welding Supplies, Ltd (GWS)
All rights reserved

The information in this manual may be reproduced for personal or in-house use without permission from GWS. Otherwise, no part of this manual may be reproduced in any material form or transmitted to any persons without permission from GWS or as permitted under the New Zealand Copyright Act 1994.

Contents

1.0 Recommended Safety Precautions	2
1.1 Personal Safety Warning Signs	2
1.2 Arc Welding Risks	2
1.3 Electrical Shocks	4
1.4 User Responsibilities	4
2.0 Introduction	4
2.1 Working Principle	5
2.2 Volt-Ampere Characteristics	5
3.0 Installation and Adjustment	6
3.1 Parameters.....	6
3.2 Duty Cycle & Over Heating.....	6
3.3 Welding Polarity Connection Way.....	7
3.3.1 MMA	7
4.0 Operation Control and Connectors	8
4.1 Lay out For Front And Rear Panel	8
4.2 Welding Current Adjustment	9
4.3 Arc Force Adjustment	9
4.4 Adjustment of Hot Start	10
4.5 Welding Operation	10
4.5.1 Striking Arc.....	10
4.5.2 Manipulation of Electrode	10
4.6 Welding Parameters.....	10
4.6.1 Joint Form in MMA	10
4.6.2 Electrode Selection.....	11
4.7 Arc Welding Defects & Preventative Measures	12
4.8 Operation Environment.....	13
4.9 Operation Notices	13
5.0 Warranty Schedule	14
6.0 Troubleshooting	15
7.0 Parts & Accessories	16



Features

- DC TIG Function
- Arc Force/Hot start functions
- IGBT Inverter technology makes for a smooth and stable welding output
- Convenient pre-setting function
- Readily portable weighing 20.5Kg
- Built in automatic protection functions for over heating, over current/voltage etc
- Digital amp meter



PLEASE NOTE that under no circumstances should your ARC400 be altered or changed in any way from standard factory configuration. Doing so, will void the machine warranty.

1.0 Recommended Safety Precautions

1.1 Personal Safety Warning Signs



The above safety warning signs indicate the risk of personal injury or even death. **IMPORTANT!** Hot or moving parts can cause serious injury and electric shock can kill. Use the following ARC400 operation guidelines to insure your own personal safety and for those in the immediate vicinity of your work area.

1.2 Arc Welding Risks

Ensure your personal safety and of those nearby by observing the following risks surrounding the use of this machine.

- Only qualified technicians should service, maintain or repair your ARC400.
- Only those specifically trained in Arc welding procedures should operate this machine.
- During operation, clear the work area of individuals not required in the operation, especially children.
- Adhere to precautions contained in section 5. DC voltage remains in the capacitors after the machine has been shut off and may cause electric shocks.



- NEVER TOUCH electrical parts.
- Use dry, Arc rated gloves and other protective safety gear.
- Protect yourself from work and ground using dry insulation. Make sure insulation is sufficiently covering the working area.
- Use caution when working in confined spaces, in wet environments or where falling is a risk.

CLOTHING:

Suitable clothing must be worn to prevent excessive skin exposure to UV radiation, sparks and molten metal. Flame-proof, loose fitting cotton clothing buttoned to the neck, protective leather gloves, spats, apron and steel toe safety boots are also highly recommended. In addition, use a helmet with the recommended shade lens for amperage listed in the shade chart below.

Less than 150 amps	Shade 9
150 to 250 amps	Shade 10
250 to 300	Shade 11/12
300 to 350	Shade 13

Use one shade darker for aluminium welding

FUMES AND GASES CAN BE DANGEROUS:



Welding may produce fumes and gases that are hazardous to health. When welding, keep your head out of the fumes, avoiding inhalation. Use enough ventilation and/or exhaust at the arc to keep fumes and gases away from the breathing zone. Welding with electrodes require special ventilation such as stainless/hard facing or on lead/cadmium plated steel along with other metals or coatings which produce highly toxic fumes. Keep exposure as low as possible and below Threshold Limit Values(TLV) using local exhaust or mechanical ventilation. Within confined spaces or in some circumstances - outdoors, a respirator may be required. Additional precautions are also required when welding on galvanized steel.

- Do not weld in locations near chlorinated hydrocarbon vapors; which are a result of degreasing, cleaning or spraying operations. The heat and rays of the arc can react with solvent vapors to form phosgene - a highly toxic gas.
- Shielding gases used for arc welding can displace air and cause injury or death. Always use enough ventilation, especially in confined areas, to insure breathing air is safe.
- Read and understand the manufacturer's instructions for this equipment and the consumables to be used, including the material safety data sheet. Adhere to your employer's safety practices.

ARC RAYS CAN BURN:

- Use a properly filtered shield with cover plates to protect your eyes from arc rays and sparks when welding or when observing open arc welding.

- Use suitable clothing made from durable flame-resistant material to protect your skin and that of your assistants from the arc rays.

- Protect nearby personnel with a suitable, non-flammable screen and/or warn them not to watch the arc, hot spatter or the metal.

WELDING SPARKS CAN CAUSE FIRE OR EXPLOSION.

- Remove all fire hazards from the welding area. In the event this is not possible, cover them with fire-retardant material to prevent the welding sparks from generating a fire. Important Reminder: Welding sparks and hot materials can easily fall through small cracks and openings in adjacent areas. Avoid welding near hydraulic lines and have a fire extinguisher readily available.
- Where compressed gases are to be used at the job site, special precautions should be used to prevent hazardous situations.
- When not welding, make certain no part of the electrode circuit is touching the work or ground. Accidental contact can cause overheating and create a fire hazard.
- Do not heat, cut or weld tanks, drums or containers until the proper steps have been taken to insure that such procedures will not cause flammable or toxic vapors from combusting substances inside. They can cause an explosion even though they have been "cleaned".
- Vent hollow castings or containers before heating, cutting or welding. If you do not, this could lead to an explosion.
- Connect the earth lead cable to the work as close to the welding area as practical. Earth Lead cables connected to the building framework or other locations away from the welding area increase the possibility of the welding current passing through lifting chains, crane cables or other alternate circuits. This can create fire hazards by overheating the lifting cables until they fail.



ROTATING PARTS MAY BE DANGEROUS:

- Use only compressed gas cylinders with the correct shielding gas for the process that is to be used and ensure the appropriate designed regulators are installed correctly. All hoses, fittings, etc. should be suitable for the application and should be in good working condition.
- Always keep cylinders in an upright position and securely fasten these to an undercarriage or a fixed support.
- Cylinders should be located:
 - Away from areas where they could be struck or be subjected to physical damage.
 - A safe distance from arc welding or cutting operations and any other source of heat, sparks, or flame.
- Never allow the electrode, electrode holder or any other electrically "hot" parts to touch a cylinder.
- Keep your head and face away from the cylinder valve outlet when opening the cylinder valve.
- Valve protection caps should always be in place and hand tightened except when the cylinder is in use or connected for use.

ELECTRIC AND MAGNETIC FIELDS:

Electric current flowing through any conductor causes localized Electric and Magnetic Fields (EMF). When and where possible, you should minimize exposure to EMF as much as possible.

In order to minimize EMF, here are a few steps we recommend you follow:

- Route the electrode and work cables together – Secure these with tape wherever possible.
- All cables should be put away and kept at a safe distance from the operator.
- Never coil the power cable around your body.
- Make sure the welding machine and power cable are as far away from the operator as possible.
- Connect the work cable to the workpiece as close as possible to the area being welded.
- People with heart pacemakers should keep a safe distance away from the welding area.

The equipment complies with the Class A electromagnetic compatibility which is intended for users in locations other than residential locations where the electrical power is provided by public low-voltage supply system.

1.3 Electrical Shock

- Never touch 'live' electrical parts.
- Earth clamp all work materials.
- Never work in wet or damp environments.

Avoid electric shock by:

- Wearing dry, insulated boots.
- Using dry, leather gloves.
- Never change an electrode with bare hands or wet gloves.
- Never cool electrode holders in water.
- Work on a dry, insulated floor where possible.
- Never hold the electrode or its holder under your arm.

1.4 User Responsibilities

- Read the Instructional Manual prior to using your ARC400.
- Unauthorised repairs to this equipment may endanger the technician/operator and will void your Warranty. Only qualified personnel should perform repairs.
- Always disconnect the main power source before investigating equipment malfunctions.
- Replace broken, damaged, missing or worn parts & hoses immediately.
- Equipment should be cleaned & serviced periodically.

2.0 Introduction

WELDARC Arc Series welders are general MMA arc welders which adopt the latest pulse width modulation (PWM) technology as well as an insulated gate bipolar transistor (IGBT) power module. This state-of-the-art technology will change the work frequency to medium frequency so as to replace the traditional hulking work frequency transformer with the cabinet medium frequency transformer. These machines are readily portable thanks to their small size and light weight.

WELDARC Arc Series machines are excellent performers. They have a constant current output which makes arc welding stable and the fast dynamic response speed will reduce any impact from the arc length fluctuations. There are also automatic protection features to avoid any under-voltage, over-current, and/or over-heating which might occur inside the welders. When these issues occur, the alarm on the front panel will illuminate and the output current will be cut. These safety features can prolong the machine's life and greatly improve the reliability of the welders.

WELDARC Arc Series welders can also perform DC TIG welding. Keep in mind that with TIG welding, the minimum current will output first and then rise until the arc is ignited by the lifting method. When performing MMA welding, if the electrode touches the workpiece for more than two seconds, the welding current will automatically drop to the minimum current so as to protect the electrode.

MMA	Manual Metal Arc welding
PWM	Pulse Width Modulation
IGBT	Insulation Gate Bipolar Transistor

2.1 Working Principle

The working principle of WELDARC Arc welders is shown in the flowchart below.

The single phase 110V-220V±10% work frequency (50/60 Hz) AC is rectified into DC which is then converted to a medium frequency AC (approx. 20K-40KHz) by using an inverter device (IGBT module). The voltage is further reduced by using a medium transformer (the main transformer) and then rectified by using a medium frequency (fast recovery diode), which is then is outputted by inductance filtering. The circuit adopts current feedback control technology to ensure current output stability. The welding current parameter can also be adjusted continuously to meet welding requirements.

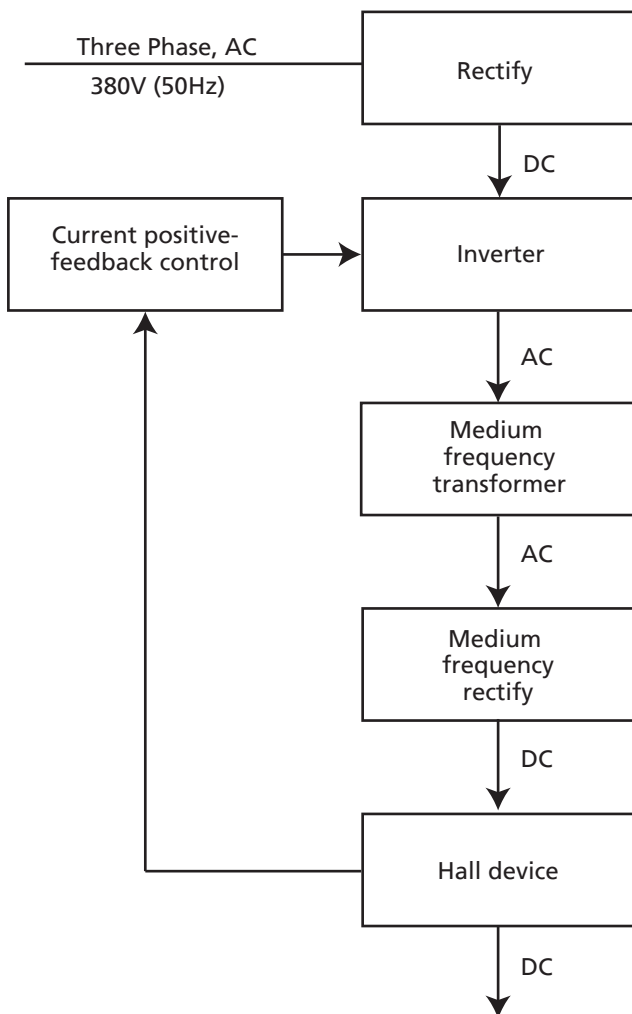

2.2 Volt-Ampere Characteristic

WELDARC Arc Series welders have excellent volt-ampere characteristics as displayed in the following graph. With MMA welding, the relation between the rated loading voltage U_2 and welding current I_2 is as follows:

$$\begin{aligned} \text{When } I_2 \leq 600\text{A, } U_2 &= 20 + 0.04 I_2 \text{ (V) ;} \\ \text{When } I_2 > 600\text{A, } U_2 &= 44 \text{ (V) .} \end{aligned}$$

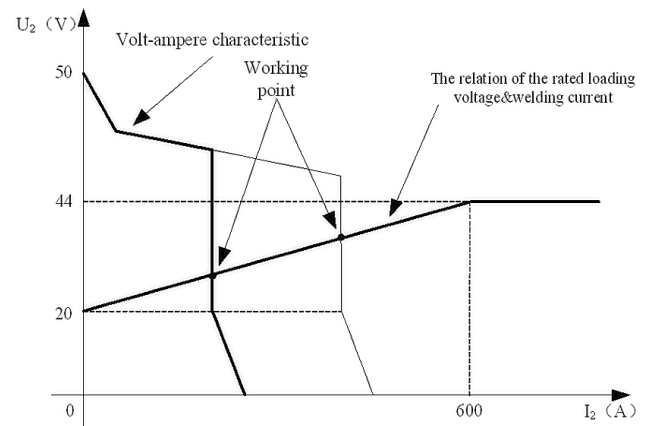

3. Installation & Adjustment

3.1 Parameters

Machine	ARC 400	
Power Supply Voltage (V)	3~380/400/415/440±10%	
Frequency (Hz)	50/60Hz	
Function	MMA	TIG
Rated Input Power (KW)	16.9	12.6
Rated Input Current (A)	26.7	19.9
Effective Current (A)	16.9	12.6
Duty Cycle (40°C 10min)	40%400A	
	60%330A	
	100%250A	
Welding Current Range (A)	5~400	
Power Factor	0.95	
No-Load Voltage (V)	15(VRD)	
Efficiency (%)	89	85
Protection Class	IP23	
Net Weight (Kg)	27	
Dimensions (mm)	470x250x400	
Insulation Class	F	
Cooling	AF	
Electrode Diameter	2.5, 3.2, 4.0, 5.0	
Electrode Type	General Purpose, Low Hydrogen, Stainless, Mild Steel, High Tensile, Cast Iron, Hard Facing, Dissimilar Metals	

Note: The above parameters are subject to change with the improvement of machines.

3.2 Duty Cycle & Over heating

Refer to the diagram on the right. The vertical axis "X" stands for duty cycle, which is defined as the proportion of time that a machine can work continuously within a certain timeframe(10 minutes). Horizontal axis I is the output current in amperage(A).

The relation between the duty cycle "X" and the output welding current "I" is shown in the figure to the right.

If the welder overheats, the IGBT over-heat protection unit inside will cut the output welding current to the minimum and illuminate the over-heat pilot lamp on the front panel. In the event this occurs, the machine should be left to idle for 15 minutes allowing the fan to cool the machine. Before operating the machine again, try reducing the welding output current and/or the duty cycle. Take special care and monitor the over-heat lamp on the panel.

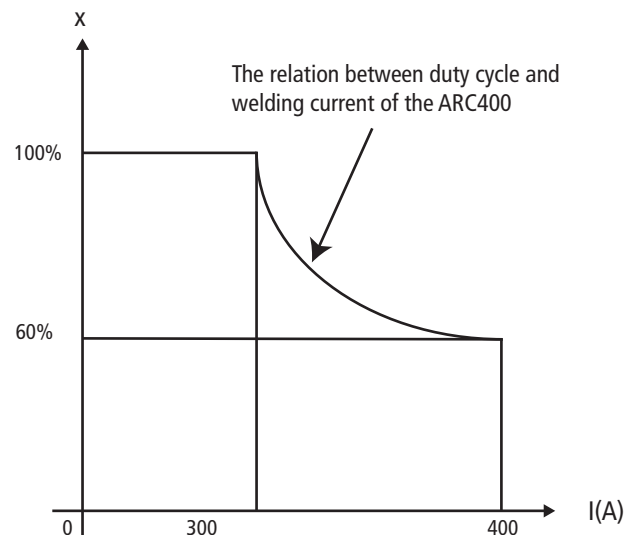

3.3 Welding polarity connection way

3.3.1 MMA

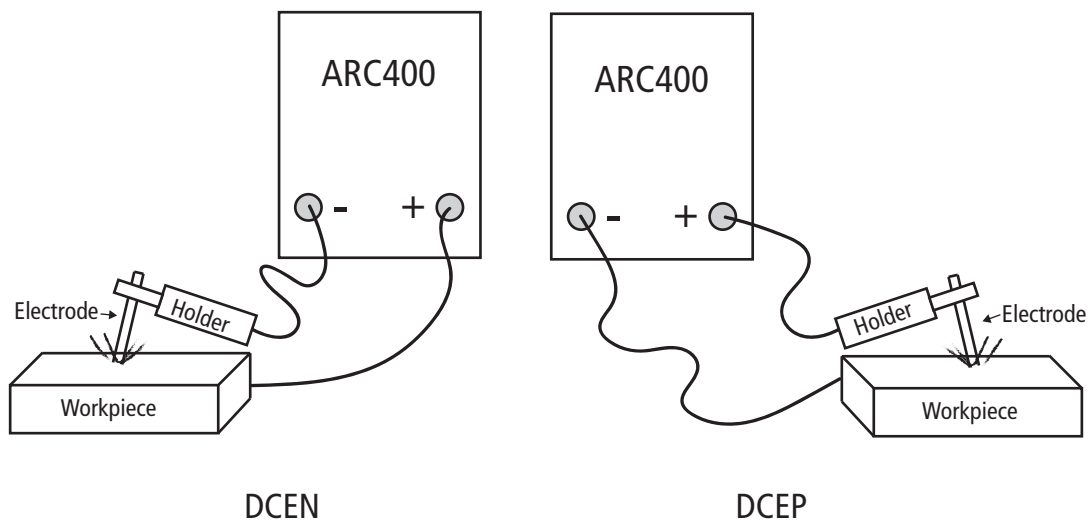

Choosing the connection of DCEN or DCEP is based on the arc stable burning condition. Different electrodes need different connections. Please refer to the electrode manual.

4.0 Operation control and connectors

4.1 Layout for front & rear panel

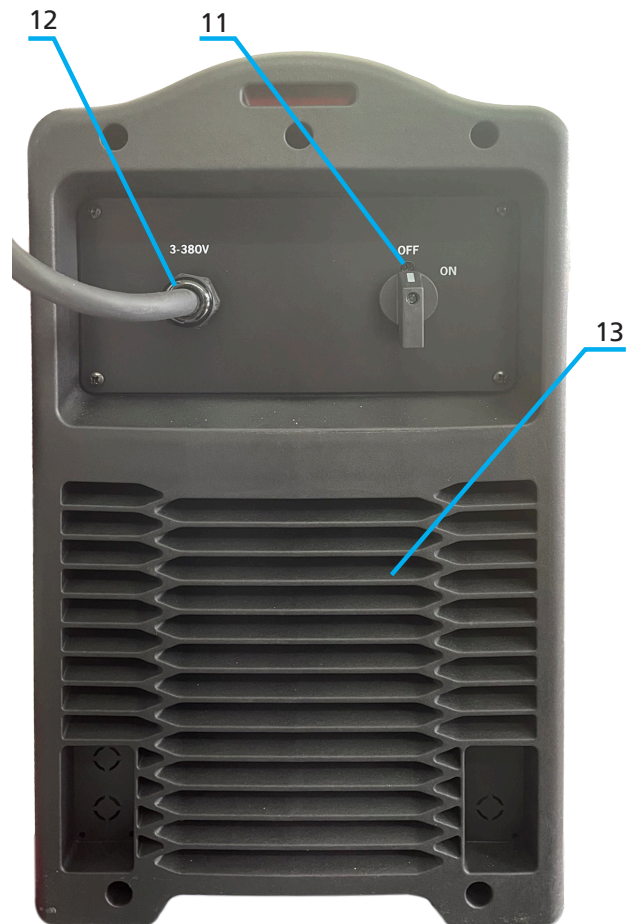
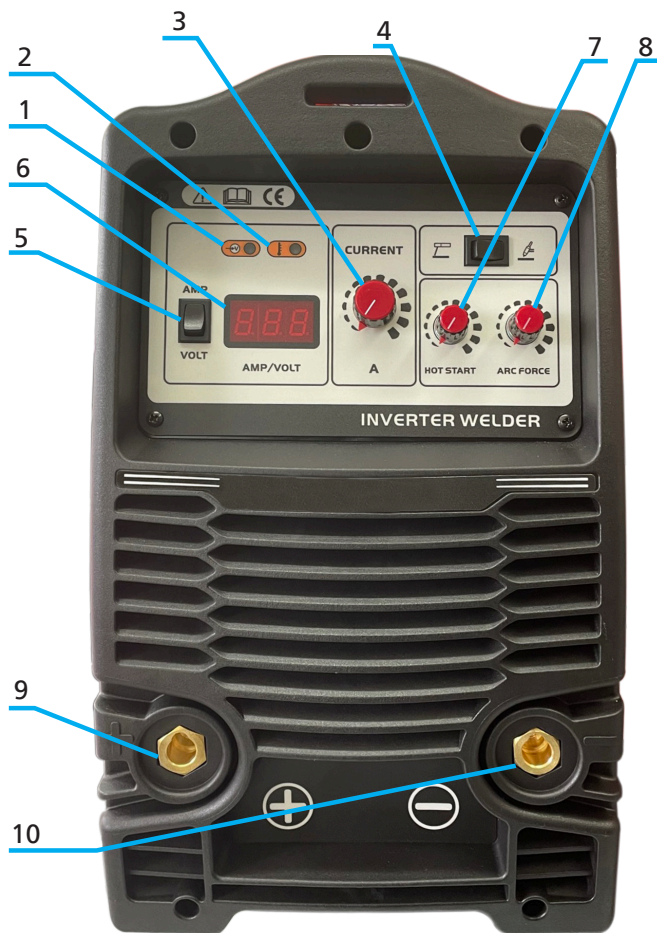

- | | |
|-------------------------------|--|
| 1. Power pilot lamp | This pilot lamp, when lit, indicates that the machine is on. |
| 2. Alarm pilot lamp | This pilot lamp, when lit, indicates protection of the machine has been activated. |
| 3. Welding current regulation | Set welding current |
| 4. Conversion switch | Choose (right), MMA.
Choose (left), TIG. |
| 5. Voltage/current selection | To select voltage/current display. |
| 6. Voltage current display | |
| 7. Hot start adjustment | |
| 8. Arc force adjustment | |
| 9. Output Joint | Negative polarity output. |
| 10. Output Joint | Positive polarity output. |
| 11. Main switch | |
| 12. Mains cable | |
| 13. Cooling fan | |

4.2 Welding Current Adjustment

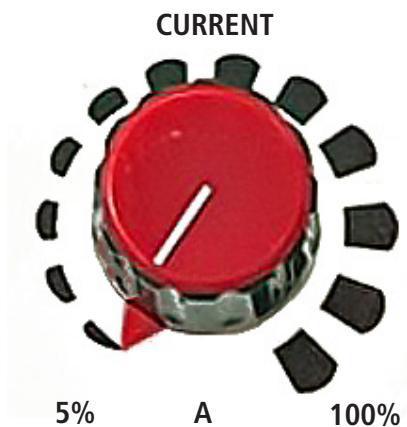

WELDarc Arc Series welders have the function to pre-set welding currents. Before operating, adjust the welding current, which will then display the output in ampere. It is convenient to set parameters and adjust accurately.

4.3 Arc Force Adjustment

When the ARC400 load voltage is under 20V, there is arc force output. The arc length is shorter and the arc force is bigger. It can prevent sticking and increase the depth of penetration.

The numbers "0-10" on the potentiometer is not actual arc force, but a proportion concept.

When the potentiometer is in the "0" position (the minimum of the arc force), the operation of arc force is not in use.

Operation remark

- In the mark of 0 (soft arc), application range: acid electrode; in the middle & high current, using basic electrode.

- In the mark of 10 (hard arc), application range: welding in the low current range (vertical up welding, surfacing welding, overhead welding, etc.)



Increase the arc force:

- Easy to strike arc
- Increase spatter
- Good root meltability
- Welding thin plate increases the dangers of penetration

Welding Position		Flat welding for flat plate butt joint	Vertical welding for flat plate butt joint	Horizontal fix welding for pipe butt joint	Vertical fix welding for pipe butt joint
Workpiece thickness (mm)		8~12	8~12	Φ114x17	Φ114x17
Continuous welding	Gap (mm)	2.5~3.2	2.5~3.2	2.5~3.2	2.5
	Root face size (mm)	~	~	~	~
	Electrode diameter (mm)	3.2	3.2	2.5	2.5
	Backing welding current (A)	70~80	75~85	60~70	70~80
Intermittent welding	Gap (mm)	3.2~4	3.2~4	3.2~4	2.5~3.2
	Root face size (mm)	1~1.5	1~1.5	1~1.5	1~1.5
	Electrode diameter (mm)	3.2~4	3.2~4	3.2	3.2
	Backing welding current (A)	80~110	100~110	90~110	90~110

4.4 Adjustment of Hot Start

The number "0~10" on the potentiometer is not actual arc force, but a proportion concept. Turning the hot start knob clockwise increases the hot start current duration and makes for easier striking. There are no actual added current values around the knob. Hot start adjustment is chosen to be based on the electrode diameter and workpiece thickness.

Operation remark

- It is available in the striking arc only.
- The interval time for hot start is 3 sec.



4.5 Welding Operation

4.5.1 Striking Arc

Knocking arc: Position the electrode upright and touch the workpiece. Once the short circuit has been created, quickly lift up about 2~4 mm, and an arc will be ignited. This method is difficult to master. But when welding brittle or hard steel, it is better to use the knocking method.

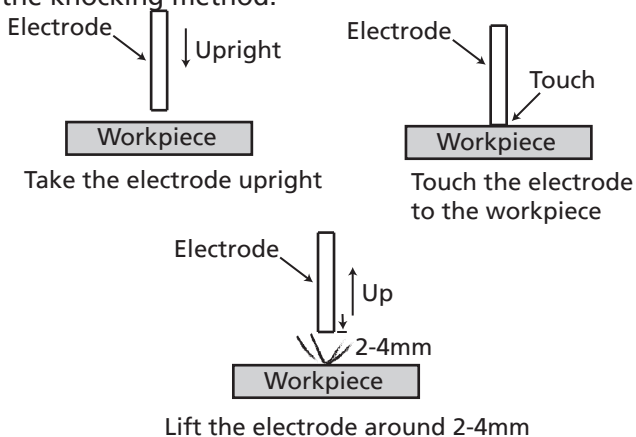

Scratch Start the electrode along the workpiece to initiate the striking arc.

4.5.2 Manipulation of Electrode

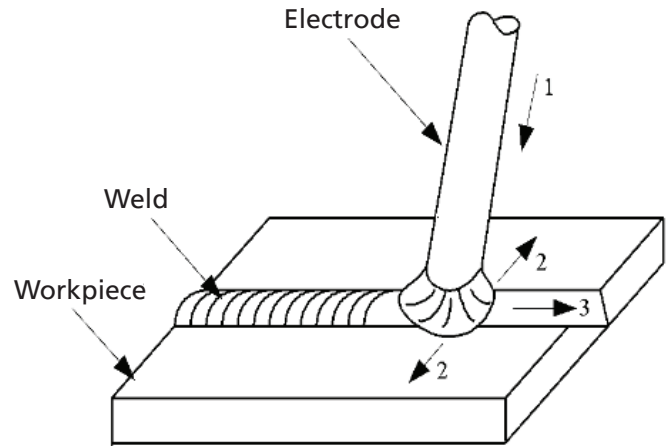

1. Electrode Moving
2. Electrode swing right & left
3. Electrode movement along the weld

In MMA welding, there are three motions being matched on the end of the electrode: the electrode moving to the molten pool along the axis, the electrode swinging right/left and the electrode moving along the welding way.

The operator can choose the manipulation of electrode based on the welding joint sharpness, welding position, electrode spec, welding current and/or operation skill, etc.

4.6 Welding Parameters

4.6.1 Joint form in MMA

In MMA welding, the common basic joint form is: butt joint, lap joint, corner joint & T joint.

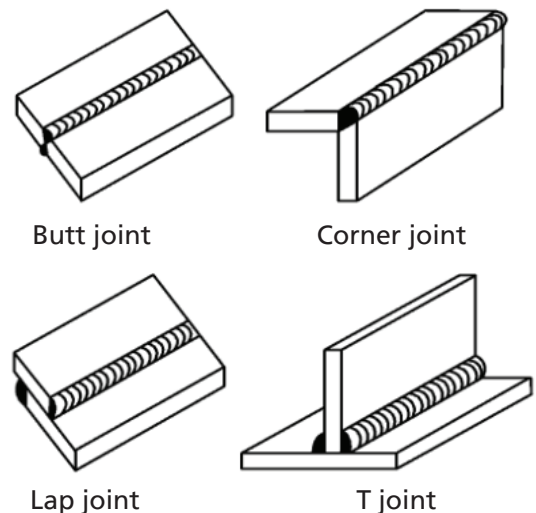

4.6.2 Electrode Selection

The electrode diameter selection is based on the workpiece thickness, welding position, joint form, welding layer, etc. Please refer to the following table.

The relation between the electrode diameter & workpiece thickness							
Workpiece thickness/mm	2	3	4~5	6~12	>13		
Electrode diameter/mm	2	3.2	3.2~4	4~5	4~6		
The welding current reference for different electrode diameters							
Workpiece thickness/mm	1.6	1.6	2.5	3.2	4.0	5.0	5.8
Welding current/A	25~40	25~40	50~80	100~130	160~210	200~270	260~300
The relation between the welding current(I)' factor(K) & electrode(d) ($I=K*d$: Carbon electrode)							
Electrode diameter/mm	1.6	2~2.5	3.2	4~6			
Factor/K	20~25	25~30	30~40	40~50			

- The electrode should be dried according to the appropriate user's manual before use. This is necessary to reduce the hydrogen of the molten pool and welding seam, and to avoid blowhole and cold crack.
- In the welding process the arc must not be too long, otherwise it will cause unstable arc burning, large spatter, light penetration, undercut, blowhole, etc. If the arc is too short, it will cause the electrode to stick.
- In MMA welding the arc length is usually equal to 0.5~1.0 of the electrode's diameter. The basic electrode's arc length should not be beyond the electrode's diameter, so it's better to choose short arc welding.

4.7 Arc Welding Defects & Preventative Measures

Issue	Cause	Preventative measures
Welding seam doesn't meet the requirement	The groove angle is incorrect. The root face and assembly gap is not equal. Welding techniques parameters are unreasonable. The welder's operation skill is low.	Choosing the proper groove angle & assembly gap, improve the assembly quality. Choosing the proper welding parameters. Improve operation skills.
Undercut	Over current. Arc length is too long. The electrode angle is wrong. Manipulation of electrode is incorrect.	Choosing the proper welding current & speed. The arc should not be drawn too long. The electrode angle should be correct. Manipulation of electrode should be correct.
Incomplete penetration	The groove angle or gap is too small, the root face is too big. Welding parameters are not suitable, or the assembly is not good. The welder's operation skill is low.	Correctly choose and process the groove size. Correctly assemble and ensure clearance. Choose suitable welding current & speed. Improve operation skills.
Incomplete fusion	The welding thermal input is too low. There is rust & dust on the side of groove. The slag between the layers is not cleared well.	Choose the correct welding parameters. Enhance the clearness of layers.
Overlap	The temperature of molten pool is too high. The liquid metal concretes slowly.	Choose parameters based on the welding position. Strictly control the molten hole size.
Crater	The crater time is short lasting. Over current in the welding of thin plate.	In the crater, the electrode should remain only for a short time in order for the electrode to be manipulated. After the molten pool is filled in with metal, move to the side to avoid a crater.
Blowhole	There is residue like oil, rust or water on the work piece surface and groove. The coating of electrode is damped & not drying. Under current or over speed when welding. The arc is too long or lean burning, the molten pool protection is not good. Over current, the coating of electrode falls off and loses protection. Manipulation of electrode is incorrect.	Clear the dust around the groove(approx 20-30mm either side). Dry the electrode according to manual. Correctly choose parameters to operate. Use the short arc operation. Welding location in the field should have protection from the wind. Don't use an invalid electrode.
Inclusion & slag inclusion	The slag clears bad in the middle layer in the welding process. Under current or over speed when welding. Welding operation is incorrect. The welding material can not match the work piece. The groove design & processing are not proper.	Choose an electrode with good slag detachability. Strictly clear the slag in the layers. Correctly choose the welding parameters. Adjust the electrode angle and manipulation method.
Hot crack	During the process of solidification, the inter crystal segregation is caused. At the same time, with the effect of welding stress, the hot crack is formed.	Strictly control the percentage of S and P in the welding material. Adjust the structure of the welding material. Adopt a basic electrode.
Cold crack	Three reasons will cause cold crack: The structure turned from the martensite. The residual stress caused by big restraint intensity. The residual hydrogen in welding gap.	Use a basic electrode with low hydrogen. Bake using the instructions before use. Remove any impure matter before use, reduce the percentage of hydrogen. Adopt the appropriate parameters and heat input. After welding, perform dehydrogenation.

4.8 Operation Environment

- 0m to 1000m above sea level
- Operation temperature range:-10°C~+40°C.
- Relative humidity is below 90%(+20°C).
- Inclination of power source not to exceed 15 degrees.
- Protect the machine against heavy rain or hot direct sunlight.
- The content of dust, acid, corrosive gas in the surrounding air or substance can not exceed normal standards.
- Take care that there is sufficient ventilation.
- There is at least 30cm free distance between the machine and wall surrounding walls.

4.9 Operation Notices

- Read section 1 carefully before attempting to use this equipment.
- Connect the ground wire with the machine directly.
- Input power must be AC as three phases, 50Hz 380V.
- In case of closing the power switch, no-load voltage may be exported. Do not touch the output electrode with any part of your body.
- Do not watch the arc without eye protection.
- Ensure good ventilation of the machine to improve duty ratio.
- Turn off the engine when the operation is finished to reduce the amount of energy sources.
- When the power shuts down automatically due to an overheating(or other) issue, don't restart the machine until the problem is resolved. Otherwise, the range of potential problems will be exacerbated.



5.0 Warranty Schedule 2021

GWS welding equipment is designed and tested for professional industrial environments.

As a guarantee of high quality, we offer a warranty. Valid only from the sale by GWS or an accredited distributor of the equipment or product.

In no event shall the warranty period extend more than the time stated. The warranty period includes parts and labour. GWS reserves the right to request documented evidence of the date of purchase.

Warranty terms are for single shift operation on all equipment and product. Warranty terms are a back to base warranty. All costs associated with lodging the warranty claim, including the return of goods to the Accredited Service Provider, are the responsibility of the consumer.

Any claim under this warranty must be made within the warranty period which commences on the date of purchase on the equipment or product. For the warranty to be approved the equipment or product has to be assessed by accredited GWS personnel.

Any modifications or alterations made to the equipment or product including electrical modification will result in the equipment or product not being covered under warranty. Any failures under the warranty period that are due to incorrect operation of the equipment or product will not be covered under warranty.

Consumers are reminded to only use the product in accordance with the operating instructions. For additional operating instructions or to make a warranty claim call **0800 536 774**





Main transformers - Output inductors	3 years
Power sources - Wire feeders - Cooling units	2 years
Cooling pumps - Automation products - Ventilators - Main contactors - Wire feeder motors - Solenoid valves - Welding Masks (welding helmet)	1 year
Mig, Tig & Plasma Torches Work leads, electrode holders	3 months
Mig, Tig, Plasma consumables, Welding consumables	Nil
Gas Regulator brass body	2 years
Flowmeter, elastomer seals, O rings, gauges	1 year

6.0 Troubleshooting























S/N	Troubles	Reasons		Solutions
1	When the machine is powered on, the fan works but the power light is not on.	Light damaged or has a bad connection.		Test/repair the inside circuit of power light Pr3.
		Power PCB Failures.		Repair or change power PCB Pr2.
2	When the machine is powered on, the power light is on but the fan doesn't work.	There is something in the fan.		Clean the fan.
		The fan motor is damaged.		Change fan motor.
3	When the machine is powered on, neither the fan or power light work.	No input voltage.		Check whether there is input voltage.
		Over Voltage (input voltage is too much or too little).		Check input voltage.
4	No no-load voltage output.	There is trouble inside the machine.		Check the main circuit, Pr1 & Pr2.
5	No current output.	Welding cable is not connected with the two outputs of the welder.		Connect the welding cable to the welders output.
		Welding cable is broken.		Wrap, repair or change the welding cable.
		Earth cable is not connected or loosened.		Check the earth clamp.
6	Not easy to start arc when welding, or easy to cause sticking.	Earth cable is not connected or loosened.		Earth cable is not connected or loosened.
		Earth cable is not connected or loosened.		Earth cable is not connected or loosened.
		Earth cable is not connected or loosened.		Earth cable is not connected or loosened.
7	The arc is not stable during welding.	The arc force is to small.		Increase the arc force.
8	The welding current can not be adjusted.	The welding current potentimeter in the front panel has a bad connection or is damaged.		Repair or change the potentimeter.
9	The penetration of the molten pool is not enough (MMA).	The welding current is adjusted too low.		Increase the welding current.
		The arc force is adjusted too small.		Increase the arc force.
10	Arc blow.	Airflow Disturbance.		Use the shelter from airflow.
		The electrode eccentricity.		Change the electrode.
		Magnetic effect.		Incline the electrode to the opposite direction of the magnetic blow.
				Change the position of earth clamp.
		Use the short arc operation.		
11	The alarm light is on.	Over heat protection.	Over welding current	Induce the welding current output.
			Working time too long.	Induce the duty cycle (interval work).
		Over current protection.	Unusual current in the main circuit.	Test and repair the main circuit and drive PCB (Pr1).

Parts & Accessories



Package Includes

		WSEL5004	WELDARC® Earth Lead OKC Male 500 Amp 4 Meters 35-50mm			WSAL2504	WELDARC® ARC Lead OKC Male 500 Amp 4 Meters 35-50mm
--	---	----------	---	---	--	----------	---



Optional Extras

		SAH1000F	ArcOne Vision Welding Helmet Black 1000F			WHOTBOX	WELDARC® 5Kg Variable Temperature Electrode Hot Box
		SWFU	SAFETYARC® Blue Proban Welders Hood			WHTOBOX PE2	WELDARC® 10Kg Variable Temperature Electrode Hot Box
		SGMGLL, SGMGLXL	MIGARC® Green Long Gloves 59cm L/XL (6/Pkt)			WCHR	WELDARC® Chipping Hammer Plastic Handle
		SGMGL, SGMGLXL	MIGARC® Gold Welding Gauntlet 40cm L/XL (6/Pkt)			WBRUSHCMS	Wire Universal Brush VIP1000F Mild Steel Crevice
		WBRUSH4MS	Wire Brush 4 Row Mild Steel Wooden Handle			WBRUSHCSS	Wire Universal Brush VIP1000S Stainless Steel Crevice
		WBRUSH4SS	Wire Brush 4 Row Stainless Steel Wooden Handle				



WELDarc® E7016TC Premium Low Hydrogen Arc Welding Electrodes 2Kg/Pkt

		WEL7016252	2.5mm, 2kg
		WEL7016322	3.2mm, 2kg
		WEL7016402	4.0mm, 2kg



WELDarc® E7018 Premium Low Hydrogen Arc Welding Electrodes 2kg/Pkt

		WEL7018252	2.5mm, 2kg
		WEL7018322	3.2mm, 2kg
		WEL7018402	4.0mm, 2kg

Superon Electrode Stainless E316L-16

		WES6162002	2.0mm, 2kg
		WES6162502	2.5mm, 2kg
		WES31625HP	2.5mm, Handy pack
		WES6163202	3.2mm, 2kg
		WES31632HP	3.2mm, Handy pack
		WES6164002	4.0mm, 2kg

WELDarc® Blue E6013 General Purpose Electrodes

		WEGP2502VD	2.5mm, 2kg
		WEGP4005VD	3.2mm, 5kg
		WEGP3205VD	4.0mm, 5kg

ARC 400

Product code: WM400P