



INSTRUCTION MANUAL

IMPORTANT: Read This Instruction Manual Completely before operating this equipment. Save this manual and keep it handy for quick reference. Pay particular attention to the hazards and safety precautions provided for your protection and for the protection of those in the immediate vicinity where this device is to be used. Contact your distributor if you do not fully understand this manual or require additional information.

Contents

1.0	Recommended Safety Precautions	2
1.1	Personal Safety Warning Signs	2
1.2	Safety Precautions Preface	2
1.3	Electrical Shocks	4
1.4	User Responsibilities	4
2.0	Introduction	4
2.1	Working Principle	5
2.2	Volt-Ampere Characteristics	5
3.0	Installation and Adjustment	6
3.1	Parameters	6
3.2	Duty Cycle & Over Heating	6
3.3	Movement and Placement	7
3.4	Power supply input connection	7
3.5	Polarity Connection (MMA)	7
3.6	Assembling the equipment (TIG)	7
4.0	Operation	8
4.1	Lay out For Front And Rear Panel	8
4.2	Control Panel	9
4.3	Argon ARC Welding Operation	9
4.3.1	TIG Welding (4T Operation)	9
4.3.2	TIG Welding (2T operation)	10
4.4	Welding Parameters	11
4.4.1	Joint form in TIG/MMA	11
4.4.2	The Explanation of Welding Quality	13
4.4.3	TIG Parameters	13
4.7	Operation Environment	13
4.8	Operation Notices	13
6.0	Recommended Safety Guidelines	15
7.0	Machine & Welding Hazards	15
8.0	Warranty Schedule	16
9.0	Package Contents & Optional Extras	17

The ultimate multi-process lightweight machine, ideal for the DIY enthusiast, tradesman or farmer.

The MIG160 is MIG, TIG and STICK capable, fitted with a 10amp plug to get welding anywhere with a 10amp standard household outlet.

The MIG160 is affordable and easy to handle in a wide variety of applications, making it the ideal solution for anyone looking for high performance without needing to break the bank on several single process welders.



Features

- Multi Process MIG, TIG and STICK in one machine
- Fitted with a 10amp plug so you can plug in anywhere with a 10amp outlet
- Suitable for gas and gasless welding
- Easily switch between mild steel, aluminum and stainless steel settings
- Ideal for jobs around the home, workshop, farm or worksite.
- A light weight and portable 15kg design
- Power Factor Correction (PFC)



PLEASE NOTE that under no circumstances should your MIG160 be altered or changed in any way from standard factory configuration. Doing so, will void the machine warranty.

1.0 Recommended Safety Precautions

1.1 Personal Safety Warning Signs



The above safety warning signs indicate the risk of personal injury or even death. IMPORTANT! Hot or moving parts can cause serious injury and electric shock can kill. Use the following MIG160 operation guidelines to insure your own personal safety and for those in the immediate vicinity of your work area.

1.2 Safety Precautions Preface

- The following are explanations of dangers present while operating the machine. Please remind yourself and others of these dangers.
- Only people who are trained professionally can install, debug, operate, maintain and repair the equipment.



- NEVER TOUCH electrical parts
- Use dry, hole-free gloves and other protective safety gear
- Protect yourself from work and ground using dry insulation. Make sure insulation is sufficiently covering the working area.
- Use caution when working in confined spaces, in wet environments or where falling is a risk

CLOTHING:

Suitable clothing must be worn to prevent excessive skin exposure to UV radiation, sparks and molten metal. Flame-proof, loose fitting cotton clothing buttoned to the neck, protective leather gloves, spats, apron and steel toe safety boots are also highly recommended. In addition, use a helmet with the recommended shade lens for amperage listed in the shade chart below.

Less than 150 amps	Shade 9
150 to 250 amps	Shade 10
250 to 300	Shade 11/12
300 to 350	Shade 13
Over 350 amps	Shade 14

Use one shade darker for aluminium welding

FUMES AND GASES CAN BE DANGEROUS:



- Welding may produce fumes and gases hazardous to health. Avoid breathing these fumes and gases. When welding, keep your head out of the fume. Use enough ventilation and/or exhaust at the arc to keep fumes and gases away from the breathing zone. When welding with electrodes which require special ventilation such as stainless or hard facing or on lead or cadmium plated steel and other metals or coatings which produce highly toxic fumes, keep exposure as low as possible and below Threshold Limit Values using local exhaust or mechanical ventilation. In confined spaces or in some circumstances, outdoors, a respirator may be required. Additional precautions are also required when welding on galvanized steel.
- Do not weld in locations near chlorinated hydrocarbon vapors coming from degreasing, cleaning or spraying operations. The heat and rays of the arc can react with solvent vapors to form phosgene, a highly toxic gas, and other irritating products.

- Shielding gases used for arc welding can displace air and cause injury or death. Always use enough ventilation, especially in confined areas, to insure breathing air is safe.

- Read and understand the manufacturer's instructions for this equipment and the consumables to be used, including the material safety data sheet and follow your employer's safety practices.

ARC RAYS CAN BURN:

- Use a shield with the proper filter and cover plates to protect your eyes from sparks and the rays of the arc when welding or observing open arc welding.



- Use suitable clothing made from durable flame-resistant material to protect your skin and that of your helpers from the arc rays.
- Protect other nearby personnel with suitable, non-flammable screening and /or warn them not to watch the arc nor expose themselves to the arc rays or to hot spatter or metal.

WELDING SPARKS CAN CAUSE FIRE OR EXPLOSION.

- Remove fire hazards from the welding area. If this is not possible, cover them to prevent the welding sparks from starting a fire. Remember that welding sparks and hot materials from welding can easily go through small cracks and openings to adjacent areas. Avoid welding near hydraulic lines. Have a fire extinguisher readily available.
- Where compressed gases are to be used at the job site, special precautions should be used to prevent hazardous situations.
- When not welding, make certain no part of the electrode circuit is touching the work or ground. Accidental contact can cause overheating and create a fire hazard.
- Do not heat, cut or weld tanks, drums or containers until the proper steps have been taken to insure that such procedures will not cause flammable or toxic vapors from substances inside. They can cause an explosion even though they have been "cleaned".
- Vent hollow castings or containers before heating, cutting or welding. They may explode.
- Connect the work cable to the work as close to the welding area as practical. Work cables connected to the building framework or other locations away from the welding area increase the possibility of the welding current passing through lifting chains, crane cables or other alternate circuits. This can create fire hazards or overheat lifting chains or cables until they fail.

ROTATING PARTS MAY BE DANGEROUS:

- Use only compressed gas cylinders containing the correct shielding gas for the process used and properly operating regulators designed for the gas and pressure used. All hoses, fittings, etc. should be suitable for the application and maintained in good condition.
- Always keep cylinders in an upright position securely chained to an undercarriage or fixed support.
- Cylinders should be located:
 - Away from areas where they may be struck or subjected to physical damage.
 - A safe distance from arc welding or cutting operations and any other source of heat, sparks, or flame.
- Never allow the electrode, electrode holder or any other electrically "hot" parts to touch a cylinder.
- Keep your head and face away from the cylinder valve outlet when opening the cylinder valve.
- Valve protection caps should always be in place and hand tight except when the cylinder is in use or connected for use.

ELECTRIC AND MAGNETIC FIELDS:

Electric current flowing through any conductor causes localized Electric and Magnetic Fields (EMF). The discussion on the effect of EMF is ongoing all around the world. Until now, no material evidences show that EMF may have effects on health. However, the research on damage of EMF is still ongoing. Before any conclusions are made, we should minimize exposure to EMF as much as possible. In order to minimize EMF, we should use the following procedures:

- Route the electrode and work cables together – Secure them with tape when possible.
- All cables should be put away and far from the operator.
- Never coil the power cable around your body.
- Make sure the welding machine and power cable are as far away from the operator as possible.
- Connect the work cable to the workpiece as close as possible to the area being welded.
- People with heart pacemakers should stay away from the welding area.

The equipment complies with electromagnetic compatibility on the class A which is intended for users in any locations other than residential locations where the electrical power is provided by public low-voltage supply system.

1.3 Electrical Shock

- Never touch 'live' electrical parts
- Earth clamp all work materials
- Never work in wet or damp environments

Avoid electric shock by:

- Wearing dry, insulated boots
- Using dry, leather gloves
- Never changing electrodes with bare hands or wet gloves
- Never cool electrode holders in water
- Work on a dry, insulated floor where possible
- Never hold the electrode or holder under your arm

1.4 User Responsibilities

- Read the Instructional Manual prior to using your MIG160
- Unauthorised repairs to this equipment may endanger the technician and operator and will void your Warranty. Only qualified personnel should perform repairs
- Always disconnect mains power before investigating equipment malfunctions
- Replace broken, damaged, missing or worn parts & hoses immediately.
- Equipment should be cleaned & serviced periodically

2.0 Introduction

The MIG160 adopts the latest pulse width modulation (PWM) technology and insulated gate bipolar transistor (IGBT) power module, which allows this machine to be light weight, small and portable with a low consumption.

The MIG160 also adopts ZVS and PFC full bridge inverter technology.

In order to improve the efficiency of the power supply, this machine uses ZVS technology and phase-shifting to control the average current control mode, this results in a more efficient power factor of the power supply for remarkable improvement. On top of this, this machine is capable of performing three types of welding: MMA (Stick), MIG & TIG.

The MIG160 is suitable for all positions welding for various plates made of stainless steel, carbon steel, alloyed steel, titanium, magnesium, cuprum, etc, which is also applicable to pipe installment, mould mend, petrochemical, architectural decoration, car and bicycle repairs, handicraft and common manufacture.

- ZVS soft switch technology reduces IGBT switching loss.
- The efficiency of the machine has a lot of improvement, in the state of MMA, it can reach nearly 84%.
- The MIG160 uses the average current control mode and has built in general protection including functions for limiting pulse width, over-voltage, over-current, over-heating etc. These functions obviously improve the stability and security of the machine.
- MCU control system - instant response time to changes.
- Reduced weight of the machine improves portability

MMA—Manual Metal Arc welding

PWM—Pulse-Width Modulation

IGBT—Insulation Gate Bipolar Transistor

TIG—Tungsten Insert Gas welding

2.1 Working Principle

The working principle of MIG160 is shown as the following figure. Single phase work frequency AC 220V (50 Hz) AC is rectified into DC (about 310V), then is converted to medium frequency AC (about 44KHz) by the inverter device (IGBT), after reducing voltage by the medium transformer (the main transformer) and rectifying by the medium frequency rectifier (fast recovery diodes), and is output by inductance filtering. The circuit adopts current feedback control technology to ensure current output stability. The welding current parameter can also be adjusted continuously to meet welding requirements.

2.2 Volt-Ampere Characteristic

The MIG160 has an excellent volt-ampere characteristic, displayed in the following graph. The relation between the conventional rated loading voltage U_2 and welding current I_2 is as follows:

$$\begin{aligned} \text{When } I_2 \leq 600\text{A, } U_2 &= 14 + 0.05I_2 \text{ (V);} \\ \text{When } I_2 > 600\text{A}_2, U_2 &= 44 \text{ (V).} \end{aligned}$$

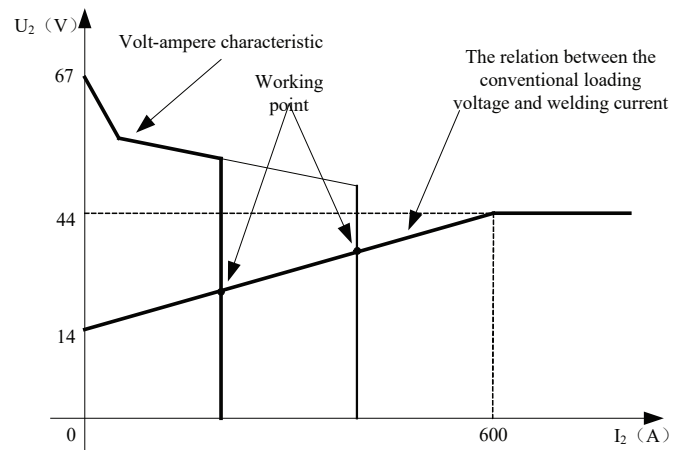
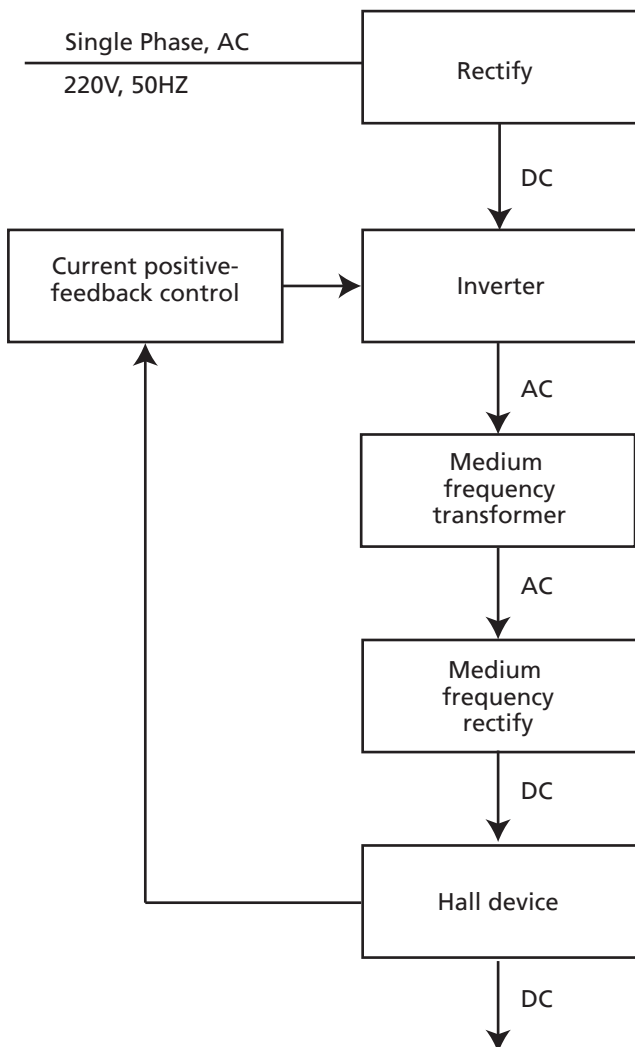

3. Installation & Adjustment

3.1 Parameters

Machine	MIG 160		
Power Supply Voltage (V)	1-200/220/230/240±10%		
Frequency (Hz)	50/60Hz		
Function	MIG	TIG	MMA
Rated Input Power (KW)	5.9	4.9	7.1
Rated Input Current (A)	24.7	20.4	29.4
Effective Current (A)	9.6	9.1	9.3
Duty Cycle (40°C 10min)	15%160A	20%160A	20%160A
	60%80A	60%90A	60%65A
	100%60A	100%70A	100%50A
No Load Voltage (V)	45(Controlled)		
Welding Current Range (A)	10~160		
Welding Voltage Range (V)	10~26		
Efficiency (%)	80		
Power Factor	0.73	0.7	0.71
Wire Diameter (mm)	Fe: 0.6/0.8/0.9/1.0 Ss:0.8/1.0 Al: 0.9/1.0 Flux 0.9 (self-shield)/1.0/1.2		
Net Weight (Kg)	15.5		
Dimensions (mm)	468x223x421		
Protection Class	IP23		
Insulation Class	F		
Cooling	AF		

Note: The above parameters are subject to change with the improvement of machines.

3.2 Duty cycle & Over heating

The letter "X" stands for duty cycle, which is defined as the proportion of the time that a machine can work continuously within a certain time (10 minutes).

The rated duty cycle means the proportion of the time that a machine can work continuously within 10 minutes when it outputs the rated welding current.

The relation between the duty cycle "X" and the output welding current "I" is shown as the right figure.

If the welder overheats, the IGBT over-heat protection unit inside it will output an instruction to cut the output welding current, and will light up the over-heat pilot lamp on the front panel. In the even this occurs, the machine should be relaxed for 15 minutes to cool the fan. When operating the machine again, the welding output current or the duty cycle should be reduced.

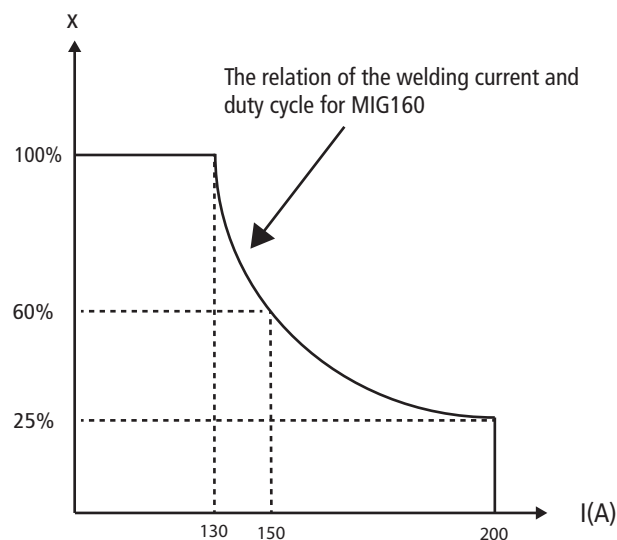

3.3 Movement and placement

Take care for the welder when moving it, ensure the machine is stood upright and refrain from sloping the machine. It can also be moved by using the handle on top of the welder. When the machine gets to the destination, it needs to be securely mounted to avoid sliding.

3.4 Power supply input connection

The MIG160 welding machines' power supply connects to 220V.

When the power supply voltage is over/under the safe work voltage, the over voltage or under voltage protection inside the welder will trigger, turning the alarm light on and cutting the current output off.

If the power supply voltage continually goes beyond the safe work voltage range, it will shorten the machines life-span.

The below measures can be used:

- Change the power supply input net - connect the welder with the stable power supply voltage of the distributor
- Set the voltage stabilization device in the front of the power cable input

3.5 Polarity Connection (MMA)

MMA (DC): Choosing the connection of DCEN or DCEP according to different electrodes. Please refer to the electrode manual.

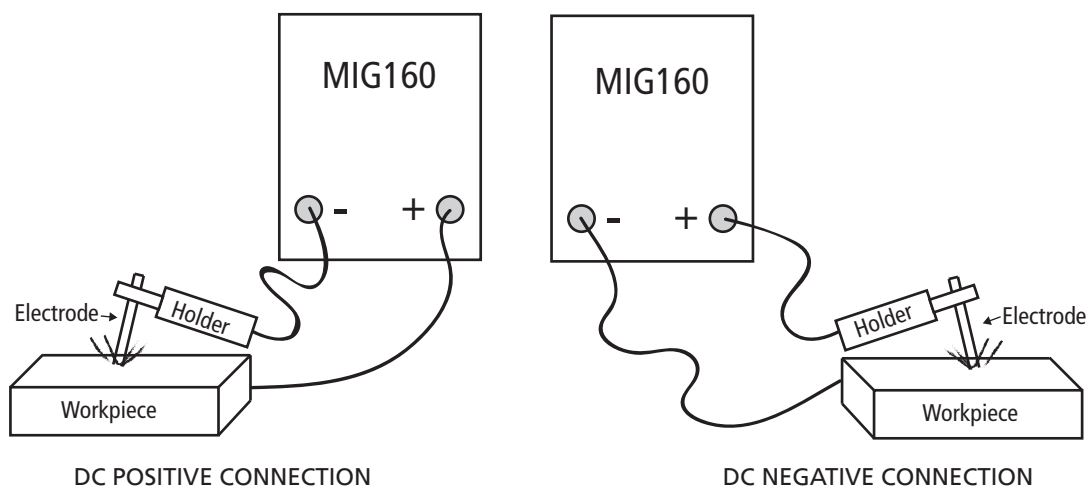

3.6 Assembling the equipment (TIG)

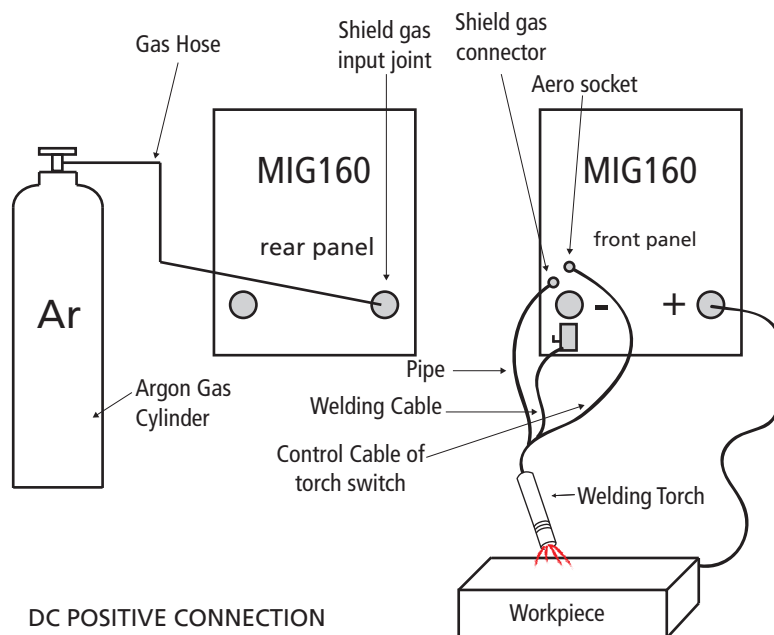

• The workpiece is connected to the positive electrode of the welding machine, with the welding torch connected to the negative electrode, called the DC positive connection. Otherwise, it's called the DC Negative connection. Generally it is usually operated as a DC positive connection when TIG welding.

• The control cable of the torch switch consists of 2 wires, pedal control of 3 wires and the aero socket has 14 leads.

4. Operation

4.1 Layout For Front And Rear Panel



- | | |
|-----------------------------|---|
| 1. Digital amp display | Displays welding current amperage |
| 2. Welding current knob | Adjusts welding current amperage |
| 3. Digital voltage display | Displays voltage |
| 4. Voltage knob | Used to adjust voltage downslope/arc force |
| 5. Power light | Is lit when the machine is powered on |
| 6. Alarm light | Is lit when the machine's protection is triggered |
| 7. Inductance knob | Used to adjust inductance |
| 8. Diameter selection | Selects specified wire diameter |
| 9. Material selection | Selects type of material being welded - Fe/Al/Ss |
| 10. TIG Selection | Selects either 2T (short) or 4T (long) when TIG welding |
| 11. Welding type selection | Selects a type of welding style - MIG/TIG or MMA |
| 12. MIG gun quick connector | The MIG welder's positive polarity output |
| 13. Positive output | The welder's positive polarity output |
| 14. Shield gas connector | Is connected to the gas input pipe of torch |
| 15. Aero socket | Is connected to torch switch control wire |
| 16. Negative output | The welder's negative polarity output |
| 17. Power source switch | Turns the machine ON/OFF |
| 18. Shield gas input joint | To connect one head of the gas hose while the other head is connected to argon gas cylinder |
| 19. Power source input | Connects to power source |

4.2 Control Panel



In different welding modes, this knob has different functions:

- MMA** Adjusts the arc force, the range is 0~10
- TIG** Adjusts the time of down slope
- MIG** Adjusts the welding voltage, the range is 10~25V

4.3 Argon ARC Welding Operation

4.3.1 TIG Welding (4T Operation)

The start current and crater current can be pre-set. This function can compensate the possible crater that appears at the beginning and end of welding. Therefore, 4T is suitable for the welding of medium thickness plates.

Pulsed TIG long welding (4T):

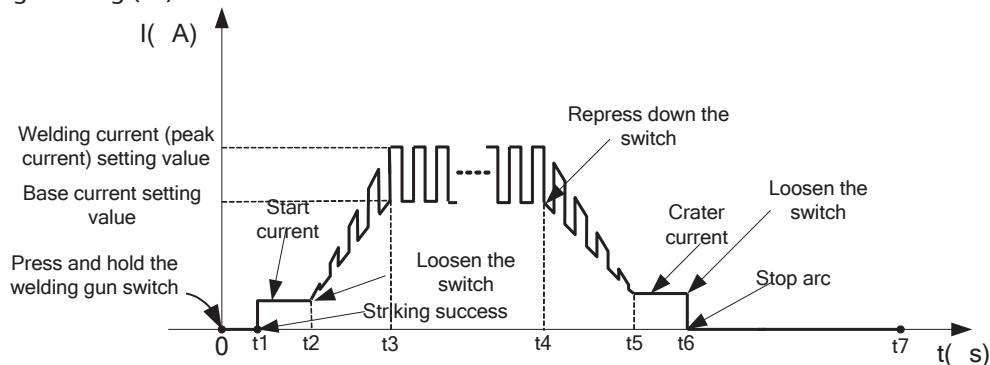

Introduction:

- 0: Press and hold the gun switch, Electromagnetic gas valve is turned on. The shielding gas starts to flow
- 0~t1: Pre flow time, adjustment range of pre flow time: 0.1~1.0S
- t1: Striking success, adjustment range of start current 10~200A
- t2: Loosen the gun switch, the output current slopes up from start current. If the output pulse function is turned on, the output current is pulsed
- t2~t3 Output current slopes up to the setting current value; adjustment range of up slope time 0~10.0S
- t3~t4: Welding process. During this period, the gun switch is loosened
- t4: Repress down the gun switch, the output current slopes down to crater current
- t4~t5: Down slope time, adjustment range of down slope time: 0~10.0S
- t5~t6: Crater current holds time; adjustment range of crater current: 10~200A
- t6: Loosen the gun switch, stop arc, and keep on argon flowing
- t6~t7: Post flow time, adjustment range of post flow time: 1.0~10.0S
- t7: Electromagnetic valve is closed and argon flowing stopped. Welding is finished.

4.3.2 TIG Welding (2T operation)

TIG short welding (2T):

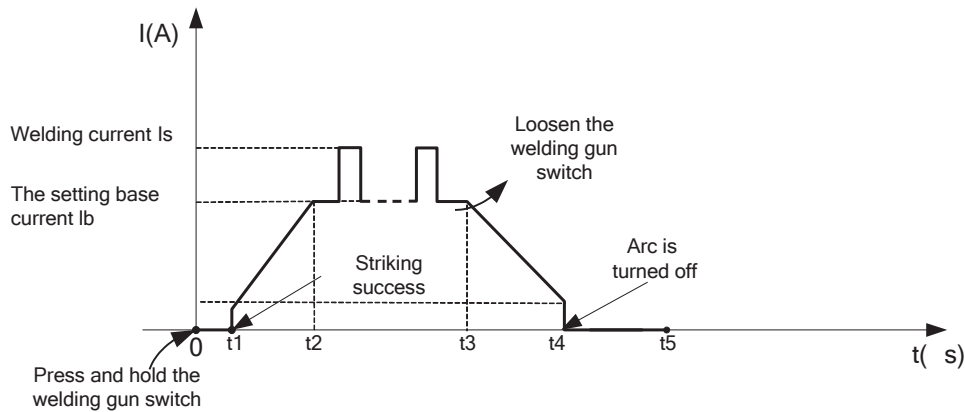

Introduction:

- 0: Press and hold the gun switch, Electromagnetic gas valve is turned on. The shielding gas starts to flow
- 0~t1: Pre flow time, adjustment range of pre flow time: 0.1~1.0S
- t1~t2: Striking success, the output current slopes up to the setting current from minimum current (10A)
- t2~t3: During the whole welding process, the gun switch is pressed and held without releasing
- t3: Loosen the gun switch, the output current slopes down
- t3~t4: The output current slopes down to minimum current (10A), stop arc; adjustment range of down slope time: 0~5S
- t4~t5: Post flow time, adjustment range of post flow time: 0.1~10.0S
- t5: Electromagnetic valve is closed and argon flowing stopped. Welding is finished

Short circuit protection function:

1. TIG /DC/LIFT: If the tungsten electrode touches the workpiece when welding, the current will drop to 30A, which can reduce tungsten spoilage, prolonging the life of the tungsten electrode, and prevent tungsten clipping.
2. TIG /DC/HF: If the tungsten electrode touches the workpiece when welding, the current will drop to 0 within 1s, which can reduce tungsten spoilage, prolonging the life of the tungsten electrode, and prevent tungsten clipping.
3. MMA: if the electrode touches the workpiece for over two seconds, the welding current will drop to the 0 automatically to protect the electrode.
Prevent arc-break function: TIG operation, Avoid arc-break with special means, even if arc-break occurs the HF will keep the arc stable.
4. TIG: If the TIG torch is pressed quickly, the welding current will drop by half, then if the TIG torch is pressed quickly again, the welding current will go back.

Notices:

- Check the condition of welding and connection units first, otherwise there may be malfunctions such as ignition sparks, gas leakages, loss of control and so on.
- Check whether there is enough Argon gas in the shield gas cylinder, you can test the electromagnetic gas valve via the switch on the front panel.
- Do not let the torch aim at your hand or other parts of your body. When you press the torch switch, the arc is ignited with a high-frequency, high-voltage spark and the ignition spark can cause interferences in equipment.
- The flow rate is set according to the welding power used in the job. Turn the regulation screw to adjust the gas flow which is shown on the gas hose pressure meter or the gas bottle pressure meter.
- The spark ignition works better if you keep the 3mm distance from the workpiece to the tungsten electrode during the ignition.

4.4 Welding Parameters

4.4.1 Joint forms in TIG/MMA

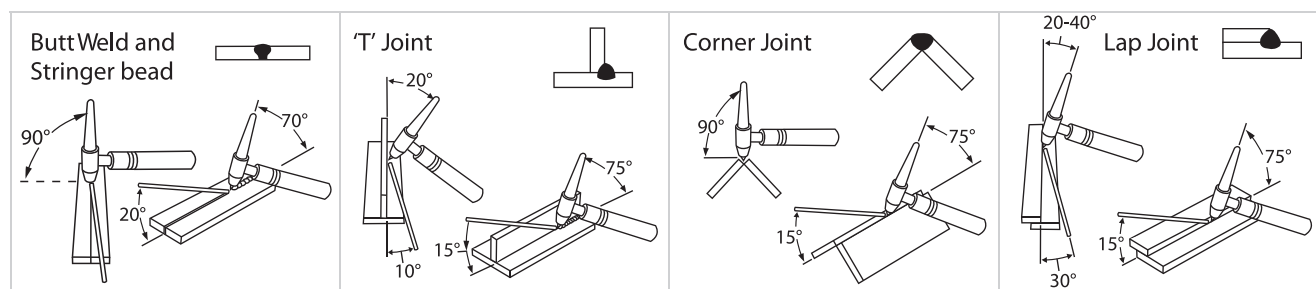

4.4.2 The Explanation of Welding Quality

The relation of welding area colour & the protection effect of stainless steel

Welding area colour	argent, golden	blue	red-grey	grey	black
Protect effect	best	better	good	bad	worst

The relation of welding area colour & the protection effect of Ti-alloy

Welding area colour	bright argent	orange-yellow	blue-purple	caesious	white powder of titanium oxid
Protect effect	best	better	good	bad	worst

4.4.3 TIG Parameters

The corresponding relationship between gas nozzle diameter and electrode diameter

Gas Nozzle diameter/mm	6.4	8	9.5	11.1
Electrode diameter/mm	0.5	1.0	1.6 or 2.4	3.2

Welding current range/A	DC Positive Connection	
	Gas Nozzle Diameter/mm	Gas Flow Rate/L · min ⁻¹
10~100	4~9.5	4~5
101~150	4~9.5	4~7
151~200	6~13	6~8
201~300	8~13	8~9

Electrode Diameter		Diameter At Tip		Constant Included Angle, Degrees	Current Range A
MM	IN	MM	IN		
1.0	.040	.125	.005	12	2-15
1.0	.040	.250	.010	20	5-30
1.6	1/16	.500	.020	25	8-50
1.6	1/16	.800	.030	30	10-70
2.3	3/32	.800	.030	35	12-90
2.3	3/32	1.100	.045	45	15-150
3.2	1/8	1.100	.045	60	20-200
3.2	1/8	.500	.060	90	25-250

Workpiece Thickness /MM	Joint Form	Tungsten Electrode Diameter/MM	Welding Wire Diameter/MM	Argon Gas Flow Rate/ L · min-1	Welding Current (DCEP)	Welding Speed/ cm · min-1
0.8	Butt	1.0	1.6	5	20~50	66
1.0	Butt	1.6	1.6	5	50~80	56
1.5	Butt	1.6	1.6	7	65~105	30
1.5	Corner	1.6	1.6	7	75~125	25
2.4	Butt	1.6	2.4	7	85~125	30
2.4	Corner	1.6	2.4	7	95~135	25
3.2	Butt	1.6	2.4	7	100~135	30
3.2	Corner	1.6	2.4	7	115~145	25
4.8	Butt	2.4	3.2	8	150~225	25
4.8	Corner	3.2	3.2	9	175~250	20

Piping Diameter Φ/MM	Tungsten Electrode Diameter/MM	Gas Nozzle Diameter/MM	Welding Wire Diameter/MM	Welding Current/A	Arc Voltage/V	Argon Flow Rate/ L · min ⁻¹	Welding Rate/ cm · min ⁻¹
38	2.0	8	2	75~90	11~13	6~8	4~5
42	2.0	8	2	75~95	11~13	6~8	4~5
60	2.0	8	2	75~100	11~13	7~9	4~5
76	2.5	8~10	2.5	80~105	14~16	8~10	4~5
108	2.5	8~10	2.5	90~110	14~16	9~11	5~6
133	2.5	8~10	2.5	90~115	14~16	10~12	5~6
159	2.5	8~10	2.5	95~120	14~16	11~13	5~6
219	2.5	8~10	2.5	100~120	14~16	12~14	5~6
273	2.5	8~10	2.5	110~125	14~16	12~14	5~6
325	2.5	8~10	2.5	120~140	14~16	12~14	5~6

4.7 Operation Environment

- Height above sea level is below 1000m.
- Operation temperature range:-10°C~+40°C.
- Relative humidity is below 90 %(+20°C). relative humidity is below 50% (40°C).
- The inclination of the power source does not exceed 10°.
- Protect the machine against heavy rain or in hot circumstance against direct sunshine.
- The content of dust, acid, corrosive gas in the surrounding air or substance can not exceed normal standards.
- Take care that there is sufficient ventilation during welding. There is at least 30cm free distance between the machine and wall.

4.8 Operation Notices

- Read section 1 carefully before attempting to use this equipment.
- Connect the ground wire with the machine directly, and refer to section 3.
- In the case of closing the power switch, no-load voltage may be exported. Do not touch the output electrode with any part of your body.
- Do not watch the arc with no eye protection.
- Ensure good ventilation of the machine to improve duty ratio.
- Turn off the engine when finished to save power.
- When power switch shuts off protectively because of failure, don't restart it until the problem is resolved. Otherwise, the range of potential problems will be exacerbated.

5.0 Troubleshooting

If there are simple troubles with your MIG160 welding machine, you can consult the following overhauling chart:











S/N	Troubles	Reasons	Solutions	
1	When the machine is powered on, the fan works but the power light is not on	Light damaged or has a bad connection	Test/repair the inside circuit of power light	
		Power PCB Failures	Repair or change control panel	
2	When the machine is powered on, the power light is on but the fan doesn't work	There is something in the fan	Clear out	
		The fan motor is damaged	Change fan motor	
3	When the machine is powered on, neither the fan or power light work	No input voltage	Check whether there is power supply	
		The fuse inside the machine is damaged	Change it (10A)	
4	No no-load voltage output (MMA)	The machine is damaged	Check the main circuit	
5	The max and min value displayed doesn't match the set value	The max value isn't in accordance	Adjust potentiometer Imin on the power board	
		The min value isn't in accordance	Adjust potentiometer Imaxin the current meter	
6	No Gas Flow (TIG)	Something in the valve	Remove it	
		Gas cylinder is closed or gas pressure is low	Open or change the gas cylinder	
		Electromagnetic valve is damaged	Change it	
7	The displayed current on the screen doesn't match output	The LED screen is broken	Change the LED screen	
8	The welding current can not be adjusted	The welding current potentiometer in the front panel has a bad connection or is damaged	Repair or change the potentiometer	
9	The penetration of the molten pool is not enough	The welding current is adjusted too low	Increase the welding current	
10	Gas always flows	Something in the valve	Remove it	
		The gas test on front panel is on	Turn off	
		The adjustment knob of pre-gas time on the front panel is damaged	Repair or change it	
		Electromagnetic valve is damaged	Repair or change it	
11	The alarm light is on	Over heat protection	Over welding current	Reduce the welding current output
			Working time too long	Reduce the duty cycle (interval work)
		Over current protection	Unusual current in the main circuit	Use a stable power supply/ ensure not too many machines are using the same power supply
		Low-Voltage Protection	Power supply fluctuates	Use a stable power supply
Over-Voltage Protection				

6.0 Recommended Safety Guidelines

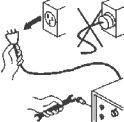
Safety precautions & recommendations include:

- Repair or replace defective cables immediately
- Never look directly at the arc except through an appropriate protective shade level lens
- In confined spaces, adequate ventilation and constant observation are essential
- Leads and cables should be kept clear of foot traffic areas to prevent accidental tripping or stumbling
- Keep fire extinguishing equipment in a handy location nearby
- Keep primary terminals and live parts effectively covered
- Never strike an electrode on any gas cylinder
- Never use oxygen for venting containers

7.0 Machine & Welding Hazards

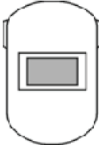
Electric shock hazard		Wear dry, insulated welding gloves while operating	
Welding electrode may cause electric shock		Insulate yourself from work & ground to prevent shock	
Fumes and gases produced during the welding process are harmful		Disconnect from power before assembling or adjusting machine	
Welding arc rays are harmful to eyes and skin		Do not operate in confined spaces or inadequate ventilation	
Read instructional manual fully before operating		Use forced ventilation or exhaust to remove welding fumes	
Seek proper training before operating		Always use a welding helmet with appropriate shade level lens	

8. Warranty Schedule 2021

GWS welding equipment is designed and tested for professional industrial environments.

As a guarantee of high quality, we offer a warranty. Valid only from the sale by GWS or an accredited distributor of the equipment or product.

In no event shall the warranty period extend more than the time stated. The warranty period includes parts and labour. GWS reserves the right to request documented evidence of the date of purchase.

Warranty terms are for single shift operation on all equipment and product. Warranty terms are a back to base warranty. All costs associated with lodging the warranty claim, including the return of goods to the Accredited Service Provider, are the responsibility of the consumer.

Any claim under this warranty must be made within the warranty period which commences on the date of purchase on the equipment or product. For the warranty to be approved the equipment or product has to be assessed by accredited GWS personnel.

Any modifications or alterations made to the equipment or product including electrical modification will result in the equipment or product not being covered under warranty. Any failures under the warranty period that are due to incorrect operation of the equipment or product will not be covered under warranty.







Consumers are reminded to only use the product in accordance with the operating instructions.

For additional operating instructions or to make a warranty claim call **0800 536 774**

Main transformers - Output inductors	3 years
Power sources - Wire feeders - Cooling units	2 years
Cooling pumps - Automation products - Ventilators - Main contactors - Wire feeder motors - Solenoid valves - Welding Masks (welding helmet)	1 year
Mig, Tig & Plasma Torches Work leads, electrode holders	3 months
Mig, Tig, Plasma consumables, Welding consumables	Nil
Gas Regulator brass body	2 years
Flowmeter, elastomer seals, O rings, gauges	1 year

Parts & Accessories



Package Includes

		WSEL2504	WELDARC® Earth Lead OKC Male 250 Amp 4 Meters 35-50mm			MMT153	MIGARC Binzel Style 15 Torch 3 Meter
		GRA	GASpro Regulator Argon Compact Flowmeter 0-25LPM				



Optional Extras

		SAH1000F	ArcOne Vision Welding Helmet Black 1000F			GRAM	GASpro® Regulator ArgonTwin Gauge Side Inlet
		MNG	MIGarc® Nozzle Gel 300g Silicone Free / Non Toxic			MCART	MIGARC® Black Trolley
		SPWH	SAFETYarc® Blue Proban Welders Hood			WWCS	Water Cooler 230V 1Phase Small 580x180x230mm 5L Tank
		WSAL2504	WELDARC® ARC Lead OKC Male			MMPLN	MIGarc® Mig Pliers Multipurpose long nose
		SGMGXL	MIGarc® Gloves Gold Welding Gauntlet 40cm L/XL (6/Pkt)			MMTSG	Binzel Style Black Handle Alloy Spool Gun 3Mtr



MIGARC Binzel Style 15 Torch

		MMT153	3 Meters
		MMT154	4 Meters



MIGARC Binzel Style 24 Torch

		MMT243	3 Meters
		MMT244	4 Meters
		MMT245	5 Meters

MIGARC Binzel Style 25 Torch

		MMT253	3 Meters
		MMT254	4 Meters
		MMT255	5 Meters

MIGARC Binzel Style 36 Torch

		MMT363	3 Meters
		MMT364	4 Meters
		MMT365	5 Meters

MIGARC Binzel Style Starter Kits, MB15, 24, 25, 36

	
--	---

MIG 160

Product code: RDMM160P